

## RHLM (V2) - RETRONICS HAZARD LIGHT MODULE

Thank you for purchasing the Retronics Hazard Light Module - a discreet safety upgrade for classic vehicles.

The RHLM comes with a three year back to base guarantee from your date of purchase.

This does not affect your statutory rights.

Being fully electronic, the RHLM's flash rate is not affected by changes in resistance - even if one or more bulbs are damaged, the rest will continue to flash at the correct rate.

The RHLM is simple to install but if you are in any doubt as to your ability, please consult a qualified technician.

Feel free to email us with any questions.

### NOTES:

\*Follow the appropriate instructions for positive and negative earth vehicles.

\*\*Disconnect the battery before installation.

\*\*\*The fuse for your indicators may need upgrading as all four will operate at once, 15A is ideal.

\*\*\*\*If your vehicle has a 6v electrical system, you will need our Voltage Converter (RVCU) installed in-line to Terminal 1, as the circuit board in the Hazard Module requires +12v to operate.

\*\*\*\*\*The RHLM has built in suppression. However (just like using a modern radio, etc.) the extreme amount of RFI caused by using unsuppressed HT leads, etc. may cause issues - the indicators may flash too fast. In this case, additional suppression may be required.

### INSTALLATION INSTRUCTIONS FOR NEGATIVE EARTH VEHICLES:

- 1/ Connect Terminals 5 and 6 to the wires feeding the left & right sides of the vehicle's indicator lamps.  
Make these connections beyond the vehicle's flasher unit & switch.
- 2/ Connect Terminal 1 to +12V power, via the pull switch, using the 2A fuse and in-line fuse holder included with the kit.
- 3/ Connect Terminal 8 to +12V power, via the included 10A fuse & in-line fuse holder.  
\*Make the connections of Terminals 1 and 8 directly from the battery (before the ignition switch) so your hazard lights will work even if the ignition is off.
- 4/ Connect the module's Terminal 2 to 0V.
- 5/ Connect Terminal 3 to the dashboard indicator (Tell Lamp) feed wire, or other additional lamp of your choice.
- 6/ Mount the control knob to the dashboard, in a position & manner of your choice.  
\*If the mounting point is not ground (earth) - for example is wood - connect the switch's side contact to 0V / ground (earth) for the switch lamp to work.

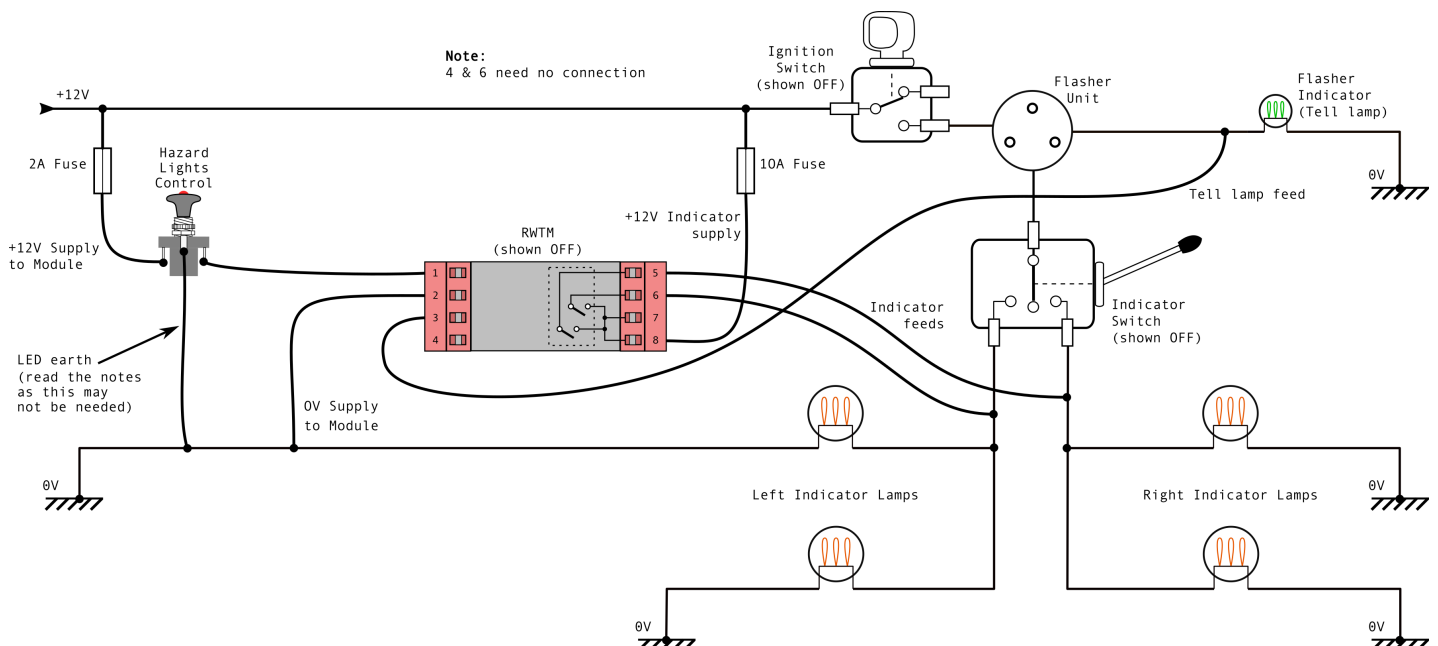

## INSTALLATION INSTRUCTIONS FOR POSITIVE EARTH VEHICLES:

- 1/ Connect Terminals 5 and 6 to the wires feeding the left & right sides of the vehicle's indicator lamps.  
Make these connections beyond the vehicle's flasher unit & switch.
- 2/ Connect Terminal 1 to +12V power, via the pull switch, and using the 2A fuse and in-line fuse holder included with the kit.
- 3/ Connect Terminal 2 to 0V.
- 4/ Connect Terminal 8 to 0V via the included 10A fuse and in-line fuse holder.  
\*Make the connections of Terminals 2 and 8 directly from the battery (before the ignition switch) so that your hazard lights will work even if the ignition is off.
- 5/ Connect Terminal 4 to the dashboard indicator (Tell Lamp) feed wire, or other additional lamp of your choice.
- 6/ Mount the control knob to the dashboard, in a position & manner of your choice.  
Connect the switch's side contact to 0V for the switch lamp to work.

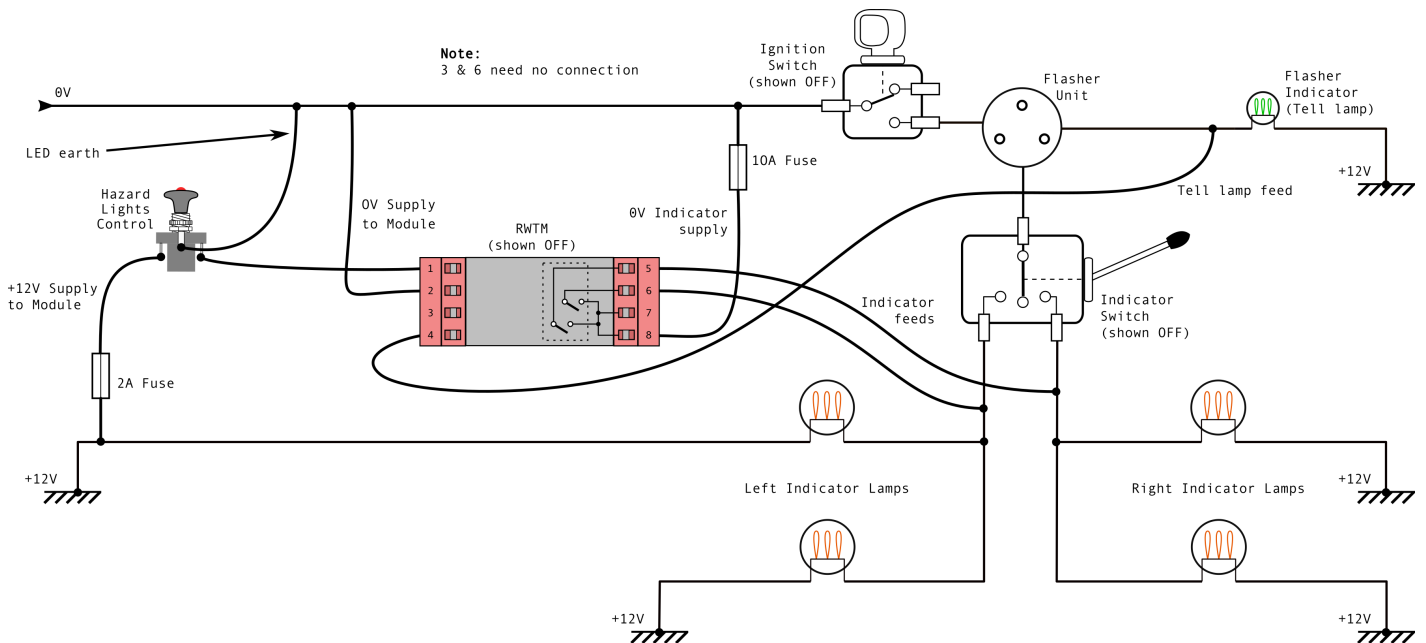

\*If the knob's mounting point is metal & not isolated from the chassis, the knob must be insulated from it's mount.

Safe & happy motoring.

*Andy & Matt*

Retronics Ltd



Retronics Ltd, The Generator Hub, Kings Wharf, The Quay, Exeter, Devon, EX2 4AN, UK.  
Registered in England, registration number: 12280789

This product is not recyclable. Please check with your local authority for suitable end of product life disposal.

\* **DISCLAIMER:** This product is UKCA, UKNI, CE & RoHS compliant. The RWTM is a generic after market product designed to be compatible with the standard wiring systems of many classic vehicles, Retronics Ltd can not guarantee compatibility with all vehicles. It is for the purchaser to satisfy themselves as to the suitability of the RWTM for their vehicle. Retronics Ltd will not be liable for any loss or damage arising from unsuitable or incorrect installations. If in doubt, consult a qualified technician.