

MGB Wire Wheel Conversion - Instructions.

Items in kit,

- 4 Hubs
- 4 Spinners
- 2 Grease Caps
- 1 Wire Wheel Spanner
- 1 Hammer
- 8 Bolts & Spring Washers for rear drums
- 4 Split Pins for rear & front hubs
- 2 Brake Locktabs

Fitting Instructions

Fitting Front Hubs.

1. Apply the hand brake, slacken the front wheel nuts and jack up the front of the car, place on axle stands. Remove both the front wheels.
2. Knock back the locktab washers on the brake callipers, unscrew both retaining bolts withdraw callipers and tie- to the upper suspension arm.
3. Remove the wheel bearing grease retaining cap, extract the split pin and unscrew the hub nut. Pull the hub and disc assembly from the axle shaft.
4. Remove the brake disc from the hub by undoing the four retaining nuts and bolts.
5. Remove the hub oil seal, retaining washer, outer bearing, shims and the inner bearing, plus the bearing spacer.
6. Drive the bearing outer races from the hub.
7. Wash the bearings, dry and examine the condition of the rollers and the races making sure the rollers are secure in the cages. If bearing surfaces are marked then replace with a new kit. Inspect the sealing surface on the oil seal collar and renew if ridged.
8. The brake disc if not too badly scored can now be fitted to the new wire wheel hub. (The TORQUE settings of the brake disc bolts are 40 to 45Lb Ft).
(Make sure that the hub marked RH is to be fitted to the right hand side of the car this is very important,)
if fitted incorrectly, you can end up losing a wheel!.
9. The outer bearing races can now be pressed into the hub making sure they are hard up against the shoulders.
Pack the bearings with grease, insert the spacer and inner bearing in the hub and press the oil seal into the hub. Fill the space between the bearing and oil seal with grease and fit the assembly onto the axle shaft.
10. At this stage it is necessary to adjust the bearing end float. Select shims to produce excessive end float and note the thickness of shims used. Shims available as follows:-

ATB4240	is	0.003in	0.08mm
ATB4241	is	0.005in	0.13mm
ATB4242	is	0.010in	0.25mm

Position the shims on the hub and against the spacer. Fit the outer bearing, retaining washer and tighten the nut. Measure the end float in the bearings,

using a dial test indicator. Remove the nut, pull the hub assembly from the axle shaft and reduce the number of shims to produce the required end float. It should be .002 to .004ins.

Reassembly the hub and replace on axle shaft tighten the hub nut to 40 to 70Lb Ft align to the next split pin hole and fit a new split pin. Recheck the hub bearing end float and adjust if necessary. Refit the new grease retaining cap but do not fill with grease.

11. Refit the brake calliper using a new locktab (BTC114) these bolts have a torque setting of 40-45Lb Ft.
12. Grease the splines of the hubs and then fit the wire wheels and tighten spinners making sure that you have the correct hub on each side i.e. RH hub on RH side of car. Remove axle stands and lower car. Recheck front spinners.

*

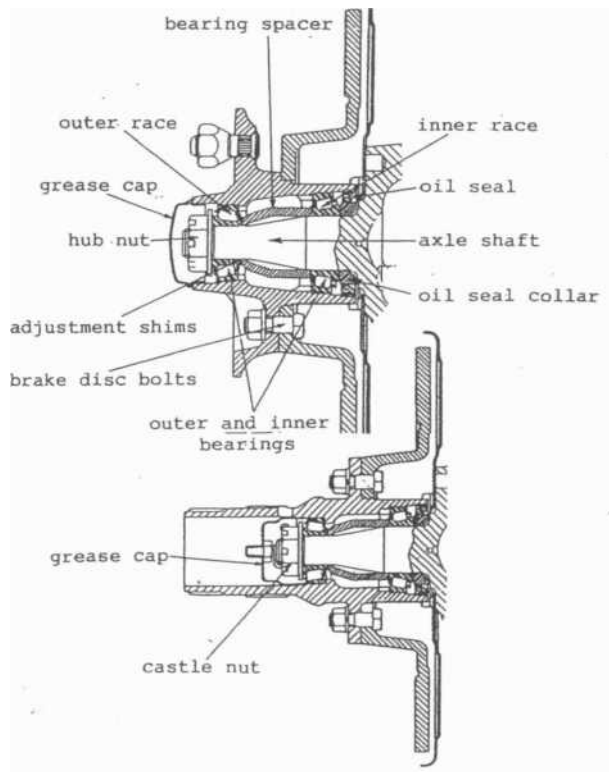

Rear

1. Remove rear wheels
2. Remove rear wheel drums
3. Remove rear hub with wheel studs
4. Replace with new rear hub from kit, using thin headed bolts and washers to attach the drums

